

EuroDrive
Made In Europe

Live Tools Product Catalogue

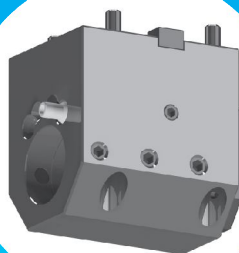

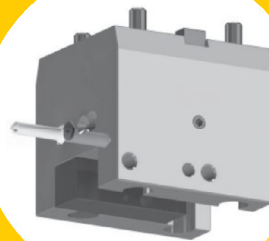
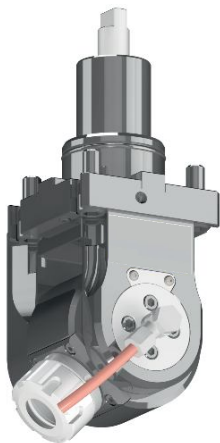
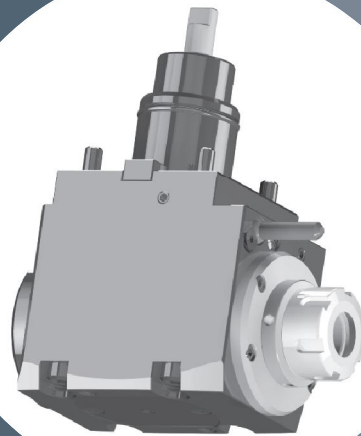
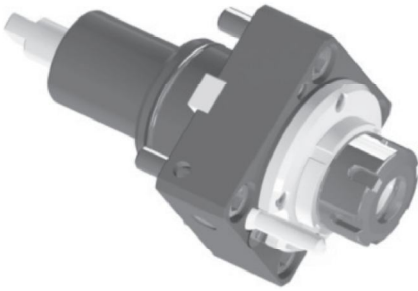

EuroDrive provides its customers high quality Driven Tools and Static Tools for CNC lathes and Machining Centres. We offer a complete range of Driven Tool Holders for all major machines including Haas, Doosan, Okuma, Mazak, Mori Seiki, Jyoti, BFW and LMW.

EuroDrive delivers products that meet the highest standards of Performance, Quality and Service. All our products are manufactured in Europe in a modern and state of the art production facility to the highest quality standards of ISO 9001.

EuroDrive develops and produces products to meet our customers high technical requirements and specifications. Our team of highly trained & skilled technicians and application engineers collaborate with our customers to develop unique solutions.

EuroDrive produces Tool Holders for CNC lathes with axial, radial and adjustable style for BMT, VDI and BOT Turrets. Static Tools are offered for Turning, Boring, Face Grooving, Cut Off and Bar Pulling operations.

EuroDrive heads can be serviced or sent in for periodic maintenance to any one of our Authorized Service Centres located in the markets we serve.



Management System
ISO 9001:2015



	PART NAME :	RGT140251321180UD	April 17, 2019	12:13
	REV NUMBER :	SER NUMBER :	9002	STATS COUNT : 1

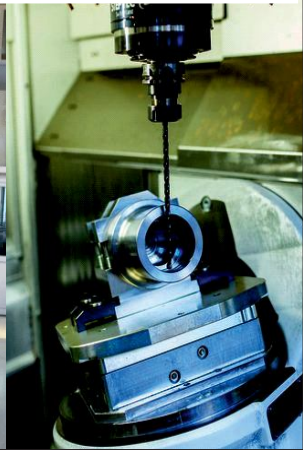
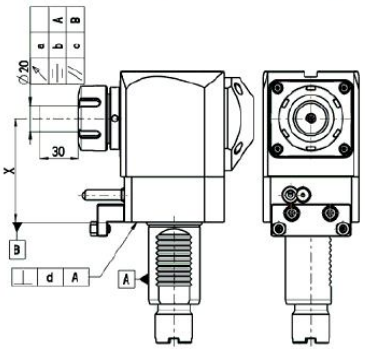

CONTENTS

Specifications

Ordering System	2
Tool Orientation	8

BMT Turret Tools

BMT 45 Live	12
BMT 45 Static	14
BMT 55 Live	16
BMT Static	19
BMT 65 Live	21
BMT 65 Static	24
HASS BOT Static	26
BMT 44 Nakamura	31
BMT 55 Nakamura	36
BMT 65 Nakamura	41
BMT 60 OKUMA	45
BMT 60 Mori Seiki	51

VDI Turret Tools











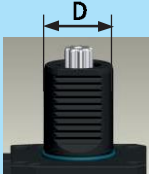





Sauter DIN 5482	56
Sauter DIN 5480	59
Diplomatic DIN 1809	63
Baruffaldi / TOEM	67
HAAS Turret	71
OKUMA	76
VDI Static DIN 69880	79

Accessories	85
--------------------------	----





Operating instructions	86
-------------------------------------	----

Maintenance Data Sheet	90
-------------------------------------	----

LIVE TOOLHOLDER SYMBOLIZATION

EDL	TURRET DATA		PRODUCT TYPE	COUPLING TYPE	TOOL GRIP	
	TYPE	D(mm)			TYPE	DIMENSION
EDL	1	40	2	5	1	32
	1 - VDI 		1 - STRAIGHT  2 - ANGULAR 	1 - DIN 5482  2 - DIN 1809 	1 - COLLET 	SIZE COLLET 16/25/ 32 /40
	2 - BMT 		3 - OFFSET STRAIGHT  4 - OFFSET ANGULAR  5 - VARIABLE ANGLE 	3 - DIN 5480  4 - TOEM  5 - STEPPED 	2 - WELDON 	WELDON upon request
					3 - SHELL MILL ARBOR 	SHELL MILL ARBOR upon request

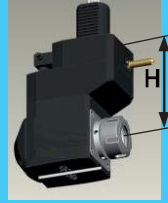
Example: EDL1- 40/251-32/2.2-80A

INTERNAL COOLING	ONLY FOR ANGULAR OFFSET STRAIGHT OFFSET ANGULAR		DETAILS CODE
	DIRECTION	H (mm)	
2	2	80	A
1 - NO 2 - YES (max 20 bar)	1 - RIGHT 		See details code table
	2 - LEFT 		Please check the pages no. 3-4
	3 - RIGHT&LEFT 		

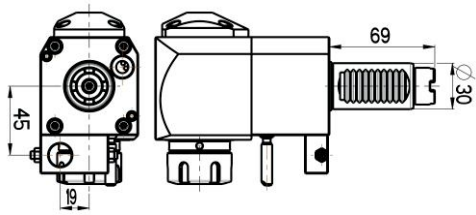
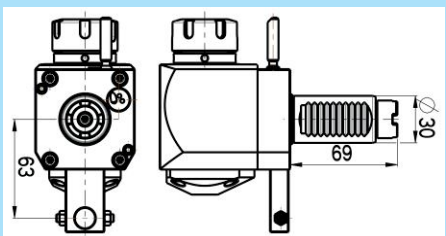
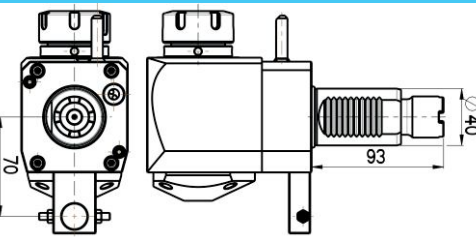
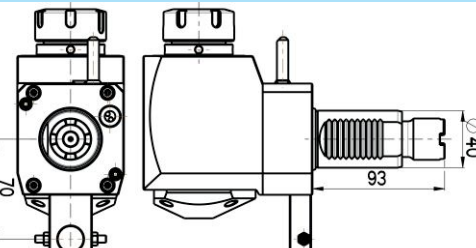

Details code		Technical details		Details code		Technical details	
JB	VDI40 OKUMA			C	VDI30 DIN1809		
JC	VDI40 OKUMA			D	VDI30 DIN1809		
JD	VDI40 OKUMA			S	VDI40 (short)		
JE	VDI40 OKUMA			D	VDI40 TOEM		
B	VDI30 DIN1809			A	VDI40 HAAS		

Details code		Technical details	
(1:2)	Ratio 1:2	$n_1=6000\text{r/min (in)}$ $n_2=12000\text{r/min (out)}$	
(2:1)	Ratio 2:1	$n_2=6000\text{r/min (in)}$ $n_1=3000\text{r/min (out)}$	
JA	VDI30 OKUMA		
JB	VDI30 OKUMA		
JA	VDI40 OKUMA		
JAS	VDI40 OKUMA same direction (in-out)		

Details code	Technical details		Details code	Technical details	
(JA) BMT60 OKUMA			(DO) BMT65 DOOSAN		
(JB) BMT60 OKUMA			(NT) BMT44 NAKAMURA -TOME		
(MS) BMT60 MORI-SEIKI			(NT) BMT55 NAKAMURA TOME		
(DO) BMT45 DOOSAN			(NT) BMT65 NAKAMURA -TOME		
(DO) BMT55 DOOSAN					

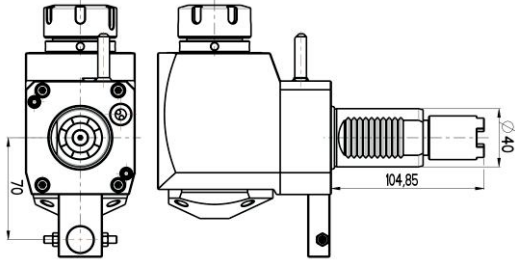
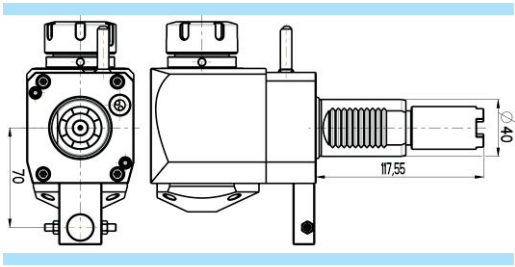
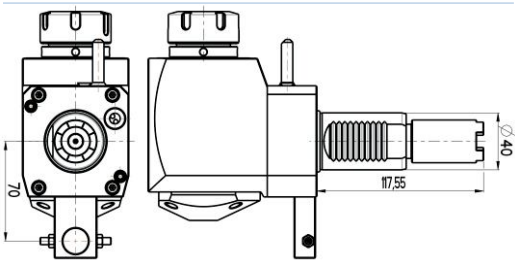
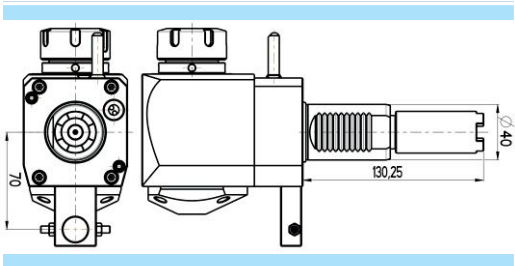
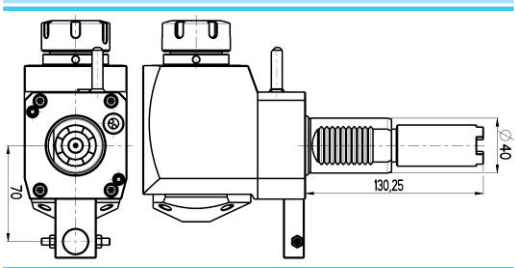
Details code	Technical details	
AS	VDI40 HAAS same direction (in-out)	
B	VDI40 HAAS	
BS	VDI40 HAAS same direction (in-out)	
C	VDI40 HAAS	
CS	VDI40 HAAS same direction (in-out)	

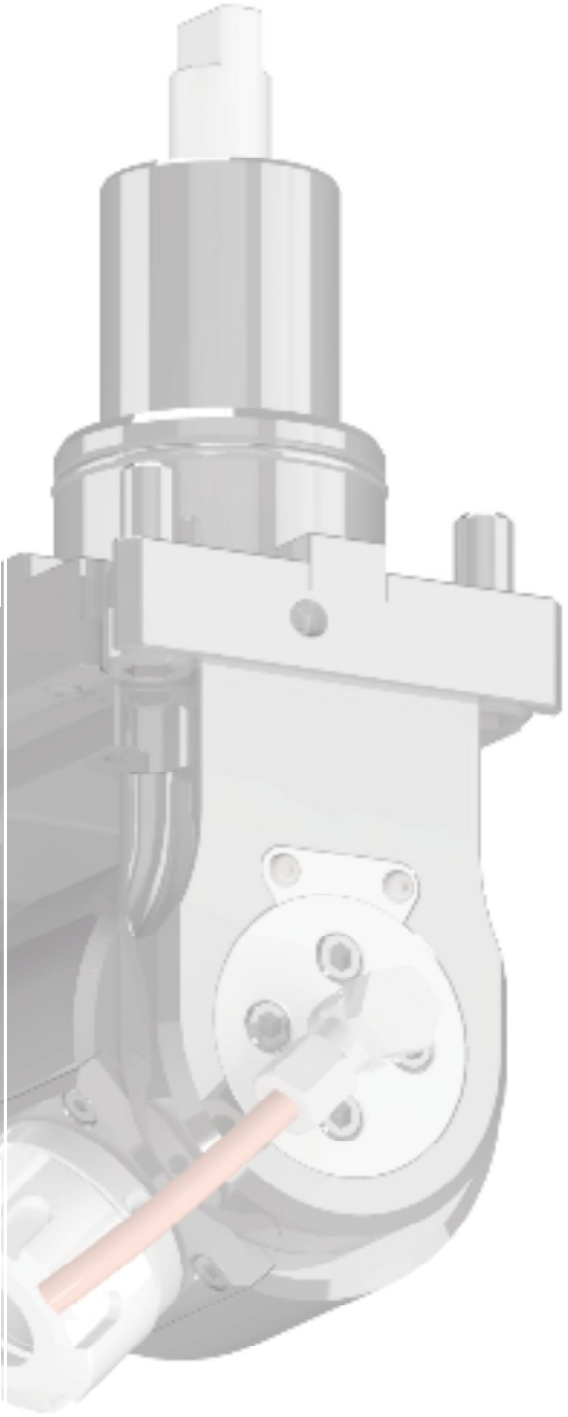

DIN 5482 Operations with VDI Disk-type turret

Axial operation

Straight tool holder

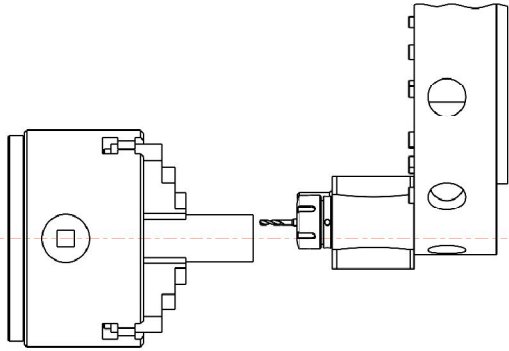

Radial operation

Angular tool holder
90° angle

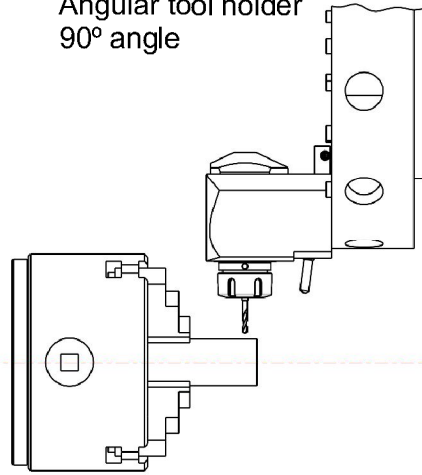

Right and Left hand versions on Disk-type Turrets

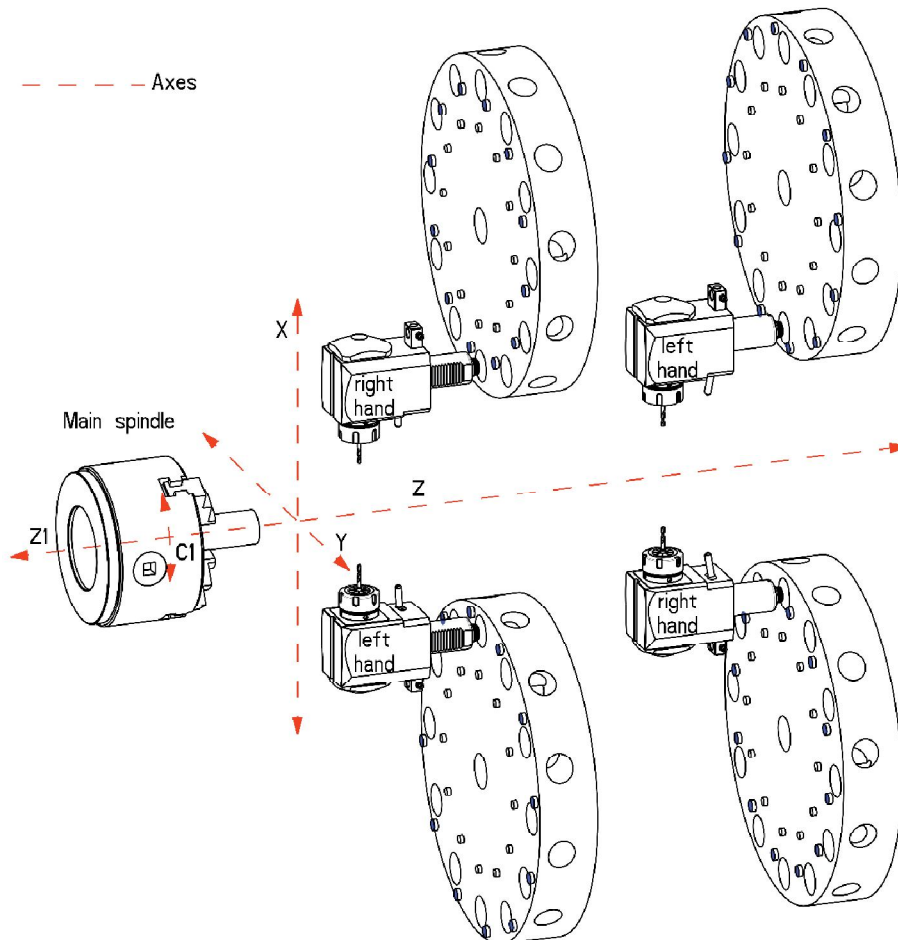

DIN 5480 Operations with VDI Star-type turret

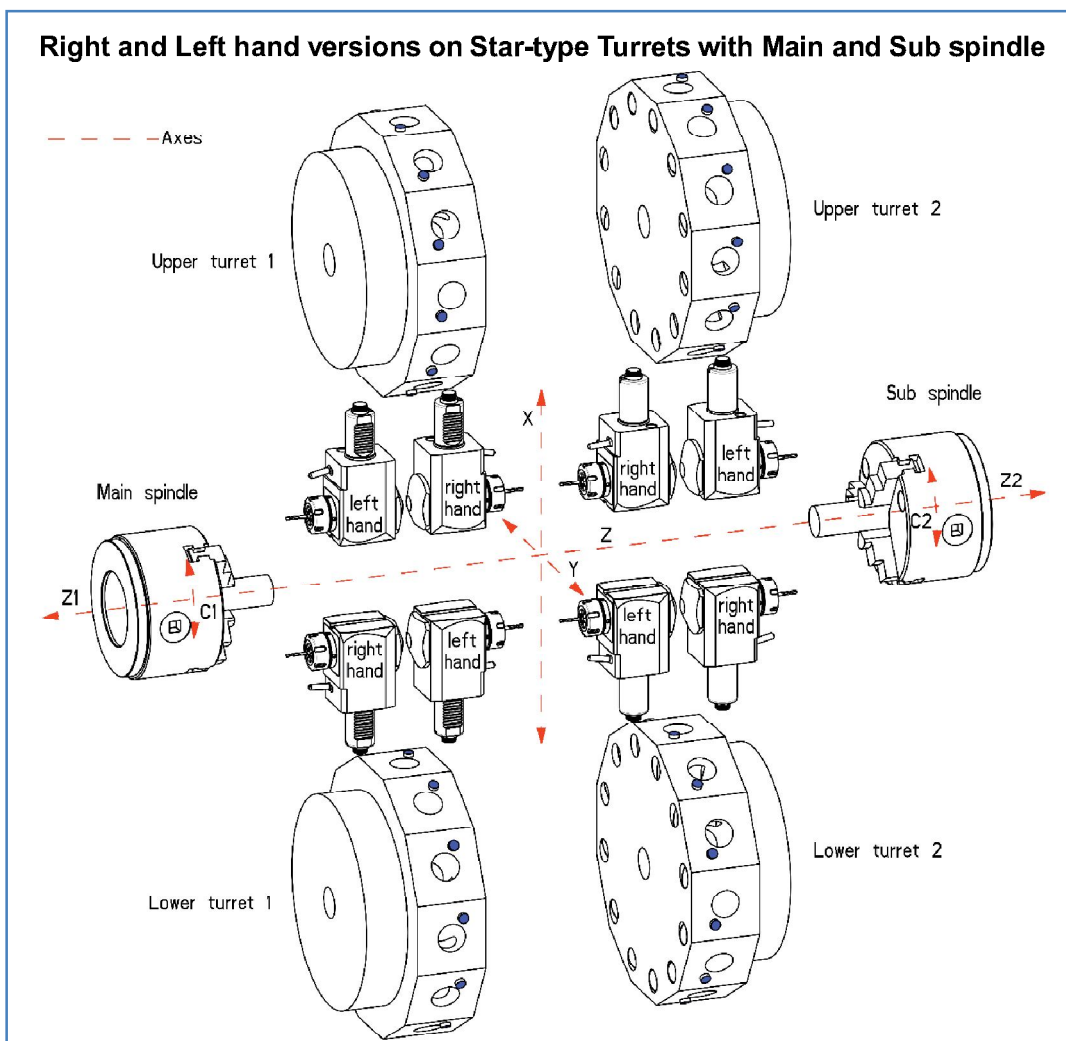
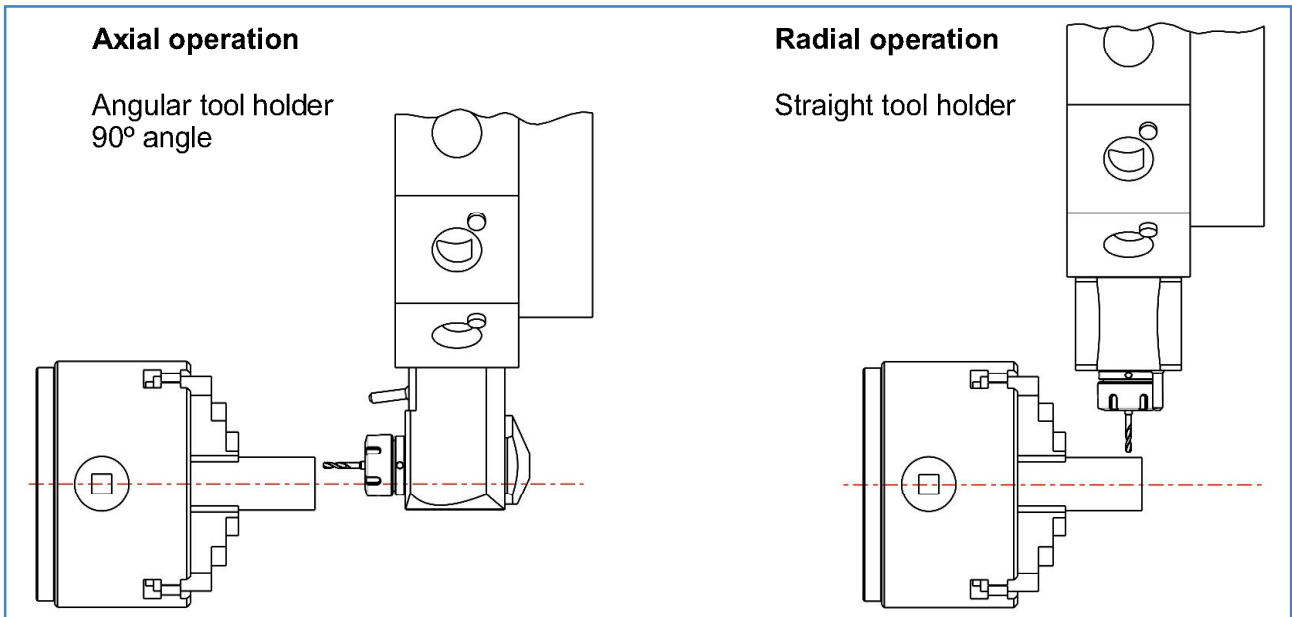

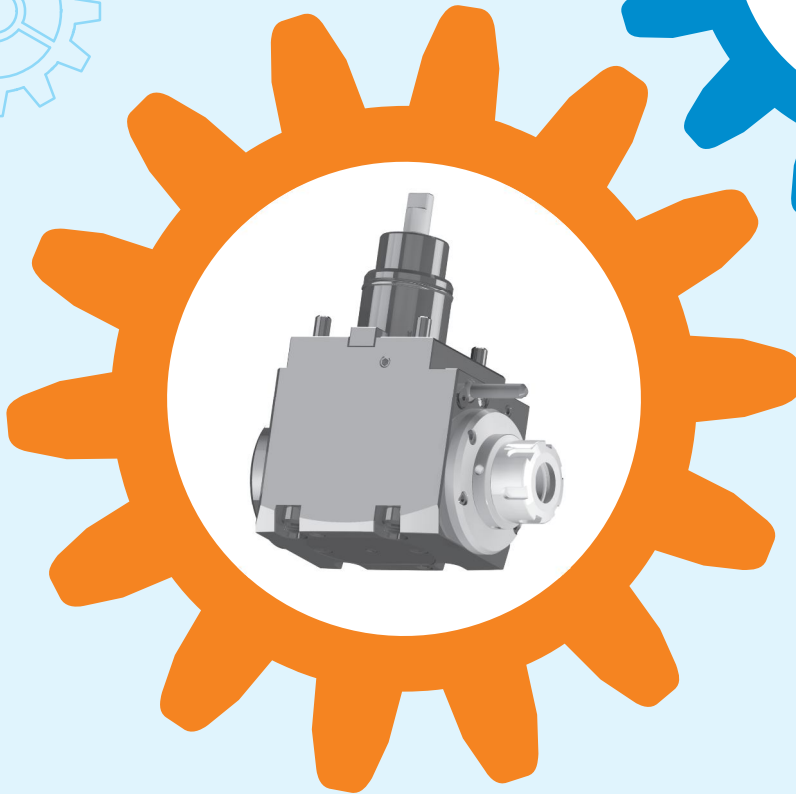
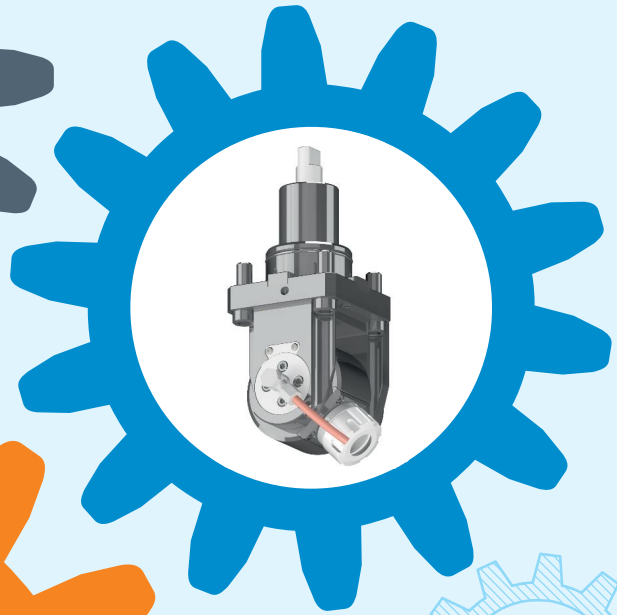
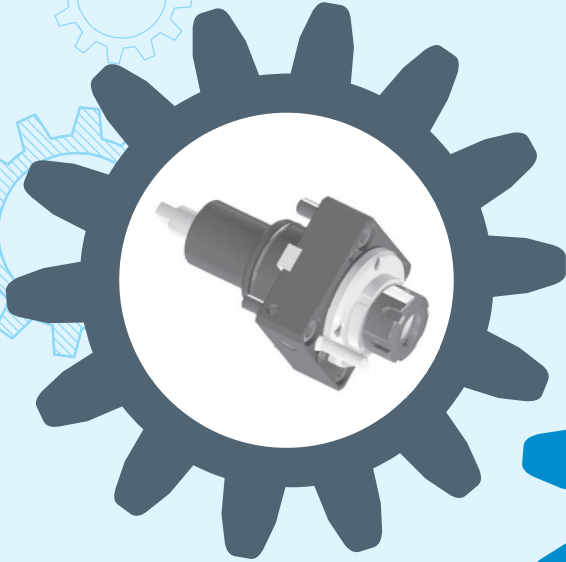

BMT TURRET TOOLHOLDERS

Suitable for:

ACE

BFW

Biglia

DOOSAN

Gildemeister/ DMG MORI

HAAS

HAAS BMT & BOT

Hardinge

Hwacheon

HYUNDAI WIA

Jyoti

Leadwell

LMW

Mazak

Mori Seiki

Muratec

Nakamura-Tome

OKUMA

VICTOR

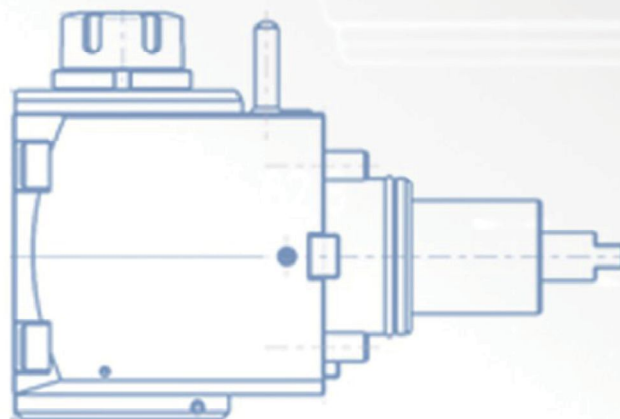
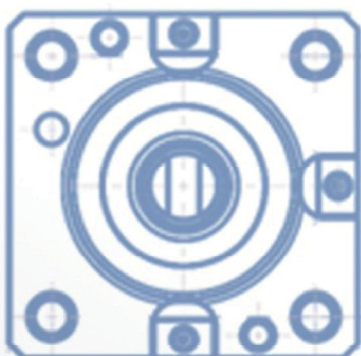

OKUMA LIVE AND STATIC TOOLHOLDERS BMT60

Okuma	LB2000 EX M
	LB2500 EX M
	LB3000 EX M

CONNECTION TURRET - OKUMA BMT60

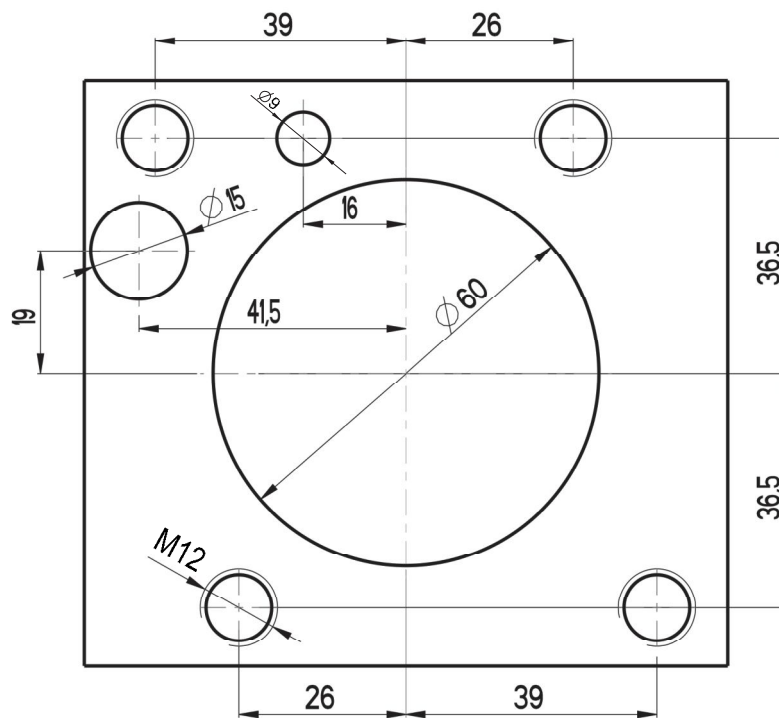

OKUMA LIVE TOOLHOLDERS BMT60

Straight BMT drilling and milling head

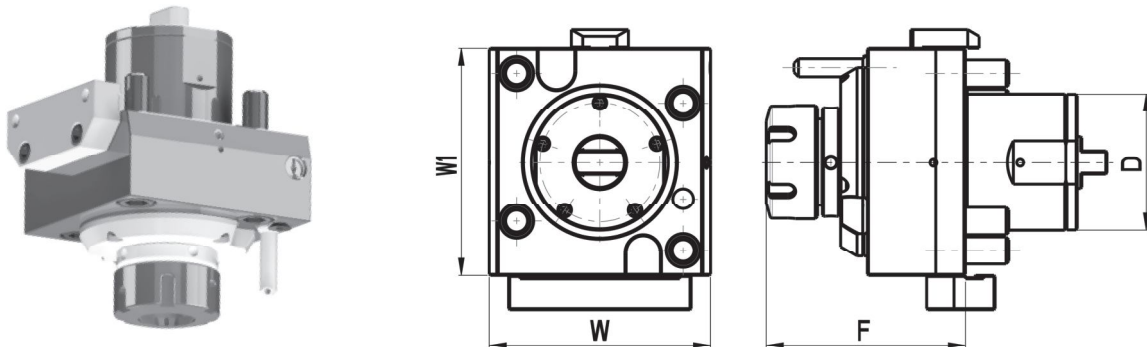

Code	D	Tool grip	Internal Cooling	F	W	W1	Torque [Nm]	Speed [rpm]	Ratio	P [bar]
EDL2-60/101-32/1(JA)	60	ER32	no	87	97	100	70	6000	1:1	-
EDL2-60/101-32/2(JA)	60	ER32	yes	87	97	100	70	6000	1:1	20

Angular BMT drilling and milling head

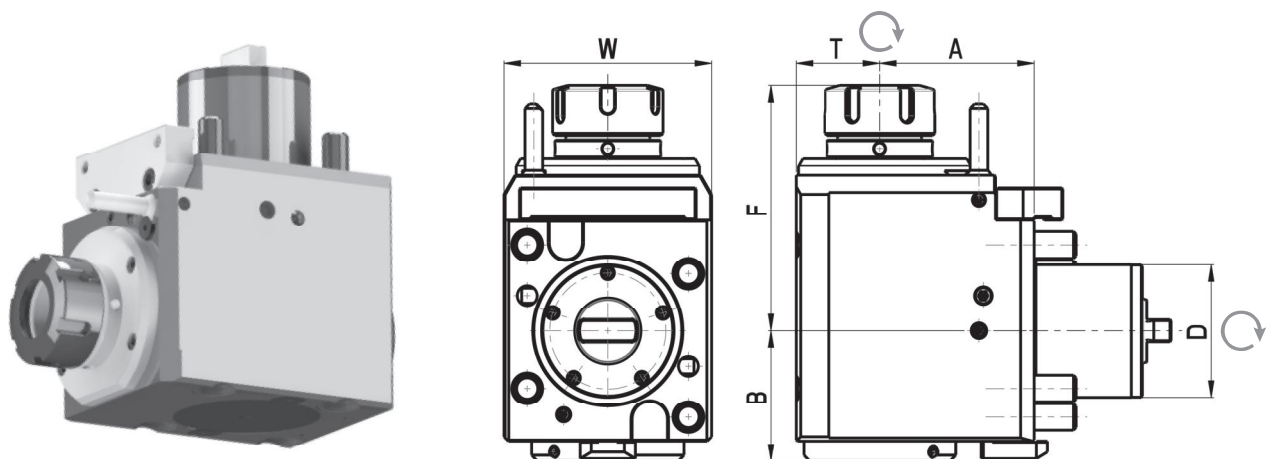

Code	D	Tool grip	Internal Cooling	Direction	A	B	F	T	W	Torque [Nm]	Speed [rpm]	Ratio	P [bar]
EDL2-60/201-32/1.3-70(JA)	60	ER32	no	right/left	70	59	111	38	94	70	6000	1:1	-
EDL2-60/201-32/2.3-70(JA)	60	ER32	yes	right/left	70	59	111	38	94	70	6000	1:1	20

* The straight, angular and variable toolholders can be equipped with Weldon shaft or shell-mill shaft upon request.

OKUMA LIVE AND STATIC TOOLHOLDERS BMT60

Okuma

LB4000 EX M

CONNECTION TURRET - OKUMA BMT60

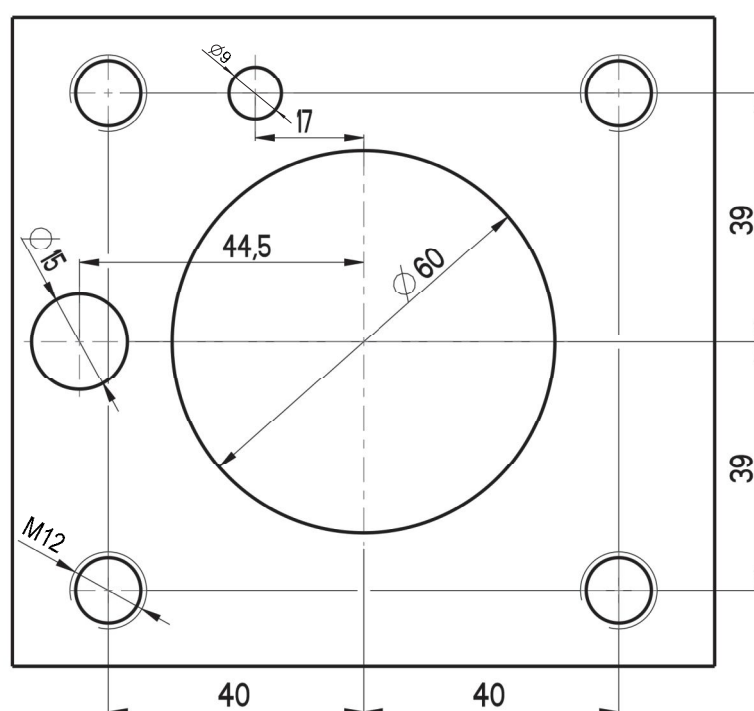

OKUMA STATIC TOOLHOLDERS BMT60

Universal turning holder

EDS OD-60x25x75(JA)
External cooling

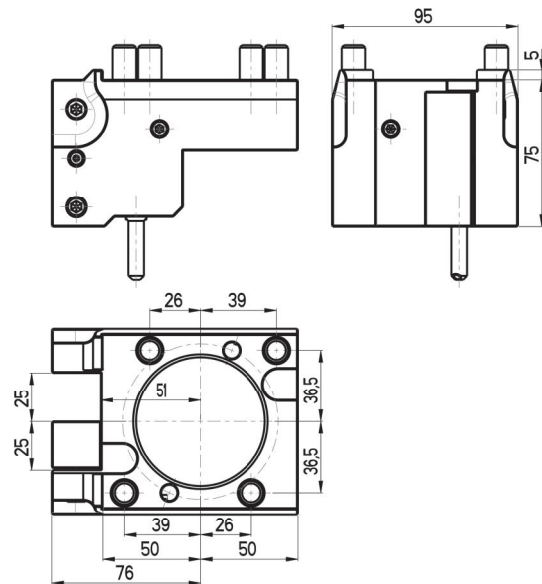
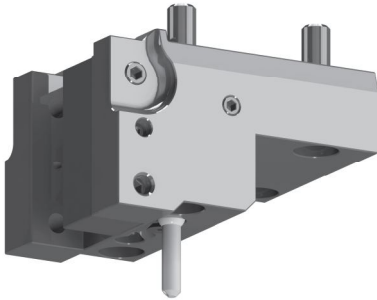

Universal turning face double holder

EDS F-60x25x70D(JA)
External cooling

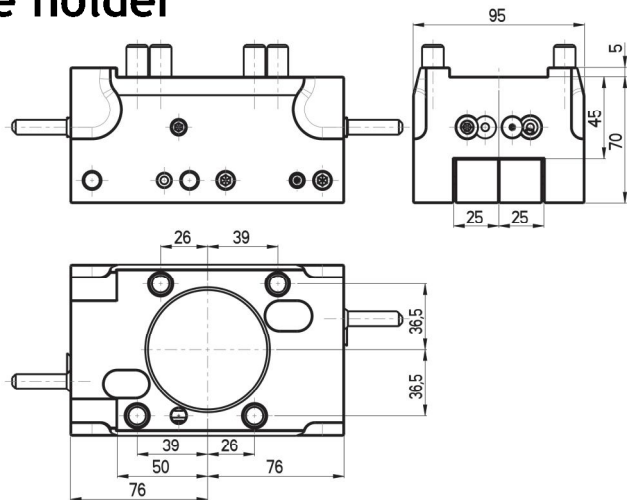
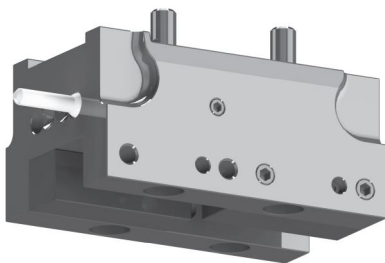

Boring bar holder

EDS ID-60x40x90(JA)
External/Internal cooling

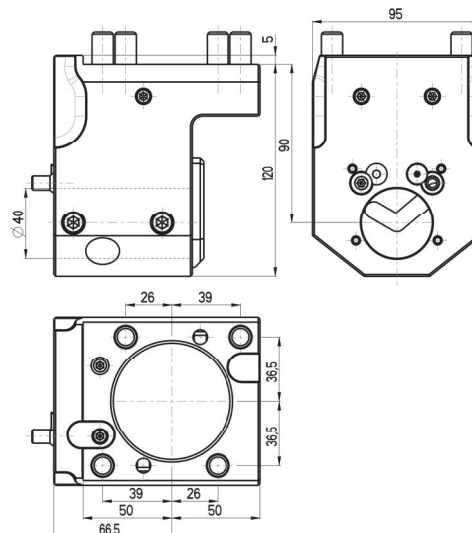
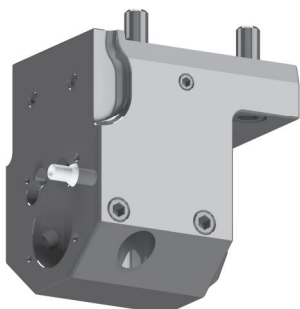

OKUMA LIVE TOOLHOLDERS BMT60

Straight BMT drilling and milling head

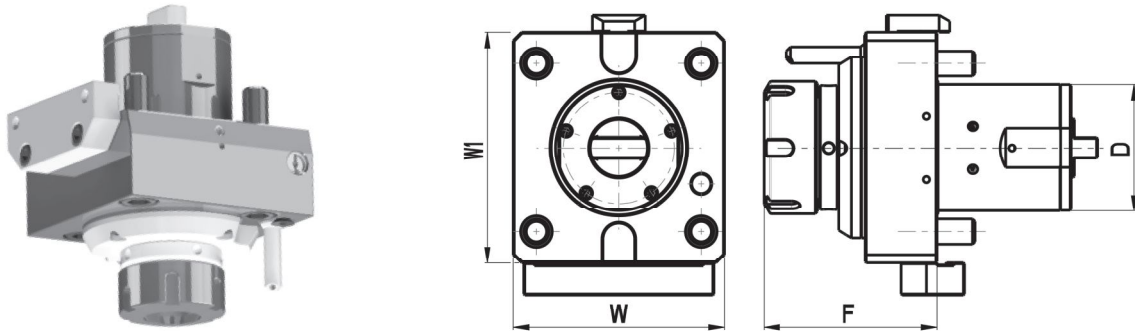

Code	D	Tool grip	Internal Cooling	F	W	W1	Torque [Nm]	Speed [rpm]	Ratio	P [bar]
EDL2-60/101-40/1(JB)	60	ER40	no	82	100	110	80	6000	1:1	-
EDL2-60/101-40/2(JB)	60	ER40	yes	82	100	110	80	6000	1:1	20

Angular BMT drilling and milling head

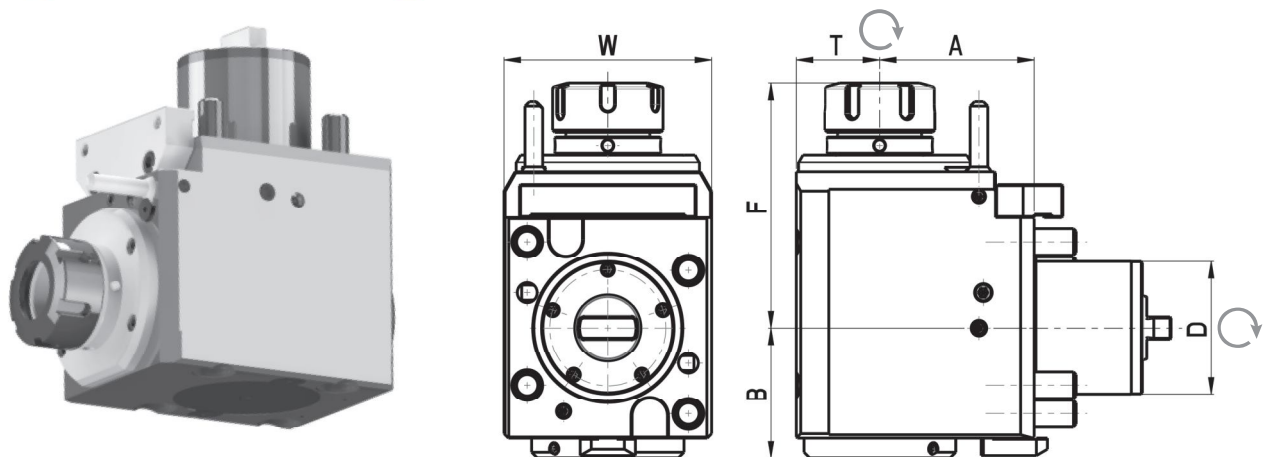

Code	D	Tool grip	Internal Cooling	Direction	A	B	F	T	W	Torque [Nm]	Speed [rpm]	Ratio	P [bar]
EDL2-60/201-40/1.3-85(JB)	60	ER40	no	right/left	85	64	121	44	100	80	6000	1:1	-
EDL2-60/201-40/2.3-85(JB)	60	ER40	yes	right/left	85	64	121	44	100	80	6000	1:1	20

OKUMA STATIC TOOLHOLDERS BMT60

Universal turning holder

EDS OD-60x25x75(JB)
External cooling

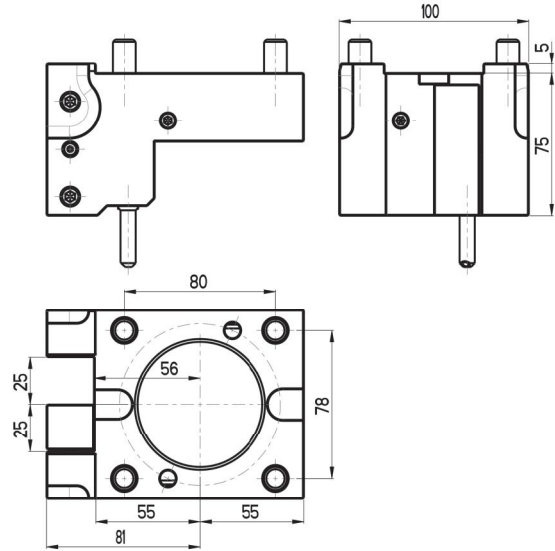
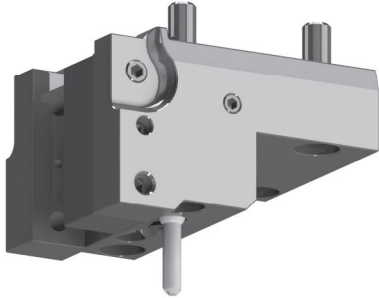

Universal turning face double holder

EDS F-60x25x70D(JB)
External cooling

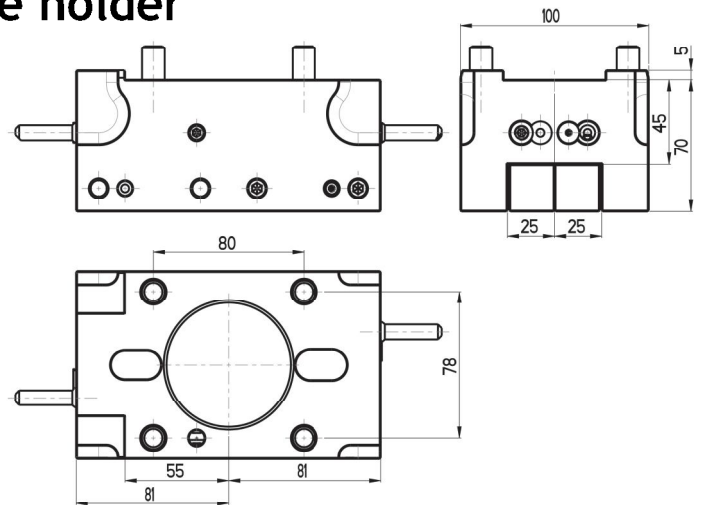
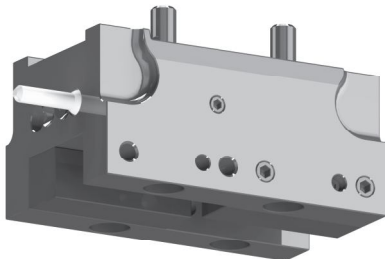

Boring bar holder

EDS ID-60x40x90(JB)
External/Internal cooling

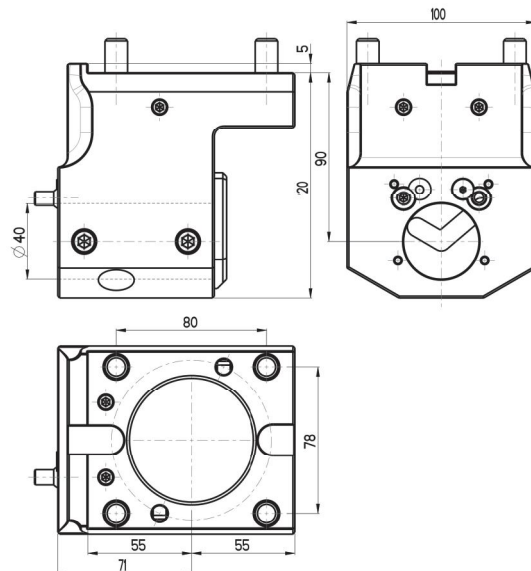
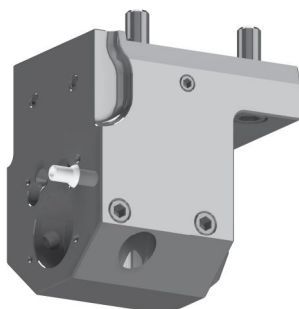



SAMTEC

Your Partner For Innovative Tooling Solutions

Samtec Tools & Accessories Pvt. Ltd.

Survey No.33/3, Behind MITCON Institute, Balewadi,
PUNE-411 045, INDIA

Mobile: +91 9325409714,

Tel No: +91 9175105689, 7507205689

web.: www.samtectools.com

ashish@samtectools.com

info@samtectools.com

Distributed by: